



PVC-DWV管
PVC-DWV FOAM CORE PIPES

南亞塑膠工業股份有限公司
NAN YA PLASTICS CORPORATION

目錄

Contents

1	1.前言 Preface
2	2.PVC-DWV管的特性 Features of the PVC-DWV Foam Core Pipes
3	3.PVC-DWV管的用途 Applications of PVC-DWV Foam Core Pipes
4	4.PVC-DWV管的物性 Physical property of PVC-DWV Foam Core Pipes
5	5.PVC-DWV管規格 Specifications of PVC-DWV foam core pipes :
5	1. PVC-DWV管規格： Specifications of PVC-DWV foam core pipes :
6	2. PVC-DWV管TS放口規格： Specification for PVC-DWV foam core pipes with TS Solvent Cement Socket :
7	6.PVC-DWV管的接合施工法（TS冷接法） Installation of PVC-DWV foam core pipes (TS unheating connection)
8	7.PVC-DWV管施工應注意事項 Instructions for installation of PVC-DWV foam core pipes

- PVC-DWV管為目前歐、美等先進國家最盛行最熱門的新產品管材，可廣泛應用於下水道、建築物的污、排水配管與無壓力場合的一般用管。由於材質非常輕（比重約0.95~1.0），價格低廉，施工與一般PVC管相同都很方便、迅速，耐外壓強度亦符合實用性之要求，尤其排水噪音的減小，為PVC-DWV管的最大特色。
 - PVC-DWV管的結構，管材內、外表皮均為不發泡材質，僅中層為PVC發泡體，故管材內、外表面仍維持與一般性PVC管同樣的光滑與平整性，其耐酸、耐鹼、耐腐蝕性亦與一般PVC管完全相同，故下水道與建築物排水系統配管的應用最為適合，用量亦最大，另外亦因具有良好的耐電壓、電氣特性，國內的固網電纜導管配管亦有採用。
 - 本公司生產的PVC-DWV管，品質優良，其各種物性與化學性，均能達到台灣CNS 14589、美國ASTM F891標準的水準，深獲業界一致的好評與愛用。
 - 目前本公司擁有全國規模最大的PVC管與PVC射出接頭的生產廠商，同時具有優越的一流生產技術，對於PVC-DWV管的產製及PVC管加工技術之進一步提升與創舉，本項產品之量產推出，使消費業界對管材的應用，可增加更有利的選擇。
 - 今後本公司仍本著服務的精神，以遍佈全國的經銷網，來為客戶作最真誠、務實的服務。
- A best-selling construction material in Europe, the U.S. and other industrialized countries, PVC-DWV foam core pipes are widely used in aqueducts, drainage systems in buildings as well as other pressure-free applications. This lightweight (at a specific gravity of 0.95~1.0) and low-cost product requires installation that is as easy and rapid as any other PVC pipe. Its pressure resistance meets all physical requirements. The most highlighted feature of the PVC foam core pipe is its minimum noise when used in drainage systems.
 - Formed by non-foam lining and coat, the PVC-DWV foam core pipe only a foam intermediate layer. Having a glowing and smooth appearance, the construction gives the PVC-DWV foam core pipe the same acid and alkali resistance and corrosion property like any other PVC pipe. This is why it is apt for aqueducts and drainage systems in buildings in large quantities. Because of its sound voltage and electric properties, this material is used in the manufacture of ducts and fittings for the Taiwanese telephone network system.
 - The quality PVC-DWV foam core pipes manufactured by this company that comply with both the physical and chemical requirements set by CNS 14589 and ASTM F891 are well positioned in the market as they have won favor of the industry.
 - Owning the largest plants and finest technologies for the manufacture of PVC pipes and PVC injected fittings in Taiwan, this company is fully committed to further improving and innovating the skills for mass production of PVC pipes, thus providing more application range to the industry.
 - Based on the service philosophy and the nationwide marketing system, this company will keep on serving its customers in an honest and practical fashion.

1.重量輕，搬運，裝卸便利：

PVC-DWV管材質很輕，比重為0.95~1.0，故搬運、裝卸與施工便利迅速，可節省人工。

2.價格低廉：

由於重量輕，故產品的價格低廉，在實用上不受限制影響之下，可節省配管工程費用。

3.耐酸鹼性，耐腐蝕性良好：

PVC-DWV管具有優良的耐酸、耐鹼耐腐蝕性，應用於下水道與建築物之廢水排水配管最為適合。

4.流體阻力小，不易附著水垢：

PVC-DWV管的管內很光滑，故流體阻力小，與其他同管徑之管材比較流量較大，亦因管內很光滑，故不易附著水垢。

5.可減小排水噪音：

PVC-DWV管的發泡層，因具有微細氣泡，可吸收噪音，故建築物排水管的排水噪音，可大幅度的減小。

6.電氣絕緣性佳：

PVC-DWV管富有良好的電氣絕緣，仍可應用於固網電纜的導管。

7.耐外壓強度良好：

PVC-DWV管的壓扁試驗，剛性(Stiffness)試驗，耐衝擊試驗等，均可符合ASTM、CNS標準的水準，甚符合實用上的要求。

8.施工簡便：

PVC-DWV管的接合施工迅速，簡便，施工之人工費用與整個管線的工程費用，均很低廉。

1.Lightweight, easy handling:

At the density of 0.95~1.0, the lightweight PVC-DWV foam core pipe is an effort-saving material of easy handling, installation and construction.

2.Low cost:

This lightweight, low-cost and practical material conserves your piping work expenses.

3.Optimal acid, alkali and corrosion resistance:

Feature optimal resistance to acids, alkali and corrosion, the PVC-DWV foam core pipe is apt for ground water works or wastewater works in buildings.

4.Free of incrustation thanks to minimum fluid resistance:

The glossy inside of the PVC-DWV foam core pipe allows minimum fluid resistance and higher fluidity when compared with other pipes of identical calibration. The glossy inside keeps incrustation from building up.

5.Minimum displacement noise:

The micro cells that form the foaming layer of the PVC-DWV foam core pipe are capable of largely absorbing noise created by drainpipes in buildings.

6.Good electrical insulation:

The fine electrical insulation property delivered by the PVC-DWV foam core pipe makes it an ideal material for conduits and telephone network cables.

7.Good flattening property:

Flattening tests, stiffness tests and pressure tests conducted on the PVC-DWV foam core pipe have delivered good flattening performance in the criteria of ASTM, CNS and satisfied all relevant requirements.

8.Easy installation:

The easy and rapid installation of the PVC-DWV foam core pipe conserves both labor and engineering cost of piping works.

3

PVC-DWV管的用途

Applications of PVC-DWV Foam Core Pipes

1. 建築工程之污、排水與透氣用管。
2. 下水道工程廢水排水用。
3. 工廠廢水排放用。
4. 固纜電纜導管用。
5. 無內壓之一般用管工程用。

1. Drain, waste, and vent works in building.
2. Sewer and drain works for under ground burial, outside of buildings.
3. Wastewater works for manufacturing plants
4. Conduits and cables
5. General non-pressure piping works



建築物排水配管 Buildings



工廠排水配管 Petrochemical plant



下水道排水配管 Sewer Engineering



固網通訊工程 Cable net-work communication engineering

4

PVC-DWV管的物性

Physical property of PVC-DWV Foam Core Pipes

■PVC-DWV管之物性

Physical property of PVC-DWV foam core pipe :

試驗項目 Test Item		品質標準 Test Value							試驗標準 Test Standard
壓扁試驗 Flattening Test		壓 ³ /5D 無破裂或裂痕現象 No cracks or ruptures.							CNS 14589
剛性試驗 Stiffness test	標稱管徑 Nominal pipe size	40	50~80	100	125~150	200	250	300	
	剛性(MPa) Stiffness (Mpa)	4.12	2.06	1.37	0.83	0.69	0.41	0.34	
	{kgf/cm ² }	{42.0}	{21.0}	{14.0}	{8.5}	{7.0}	{4.2}	{3.5}	
落錘衝擊試驗 Impact test		須試驗合格 Qualification required							



5

PVC-DWV管規格

Specifications of PVC-DWV foam core pipes :

1. PVC-DWV管規格 : (CNS 14589)

Specifications of PVC-DWV foam core pipes :

單位 : mm Unit : mm

標稱管徑 Normal pipe size		外徑及許可差 ⁽¹⁾ Outside diameter & tolerance ⁽¹⁾	厚度 Wall thickness		近似內徑 (參考) Approx. inside diameter	質量(kg/m) ⁽²⁾ (參考) Approx. weight (kg/M) ⁽²⁾
			最小 Minimum	許可差 Tolerance		
40	1 1/2"	48±0.15	3.6	+0.8	40	0.580
50	2"	60±0.15	4.1	+0.8	51	0.824
65	2 1/2"	76±0.18	4.5	+0.8	67	1.138
80	3"	89±0.20	5.4	+0.8	78	1.592
90	3 1/2"	100±0.22	5.6	+0.8	88	1.860
100	4"	114±0.23	6.6	+1.0	100	2.505
125	5"	140±0.25	7.0	+1.0	125	3.278
150	6"	165±0.28	8.0	+1.4	148	4.485
200	8"	216±0.38	9.0	+1.4	197	6.600
* 250	10"	267±0.38	10.0	+1.4	246	9.046
* 300	12"	318±0.38	11.5	+1.6	294	12.405

註/ Note :

1. 外徑係指任意垂直兩方向之外徑算術平均值。
2. 質量之計算係以最小厚度加厚度許可差之1/2為計算厚度，並以比重為1.0而計算者。
3. 下水道用PVC-DWV管之顏色為橘紅色。
4. 一般用或固網用之PVC-DWV管顏色為淺灰色。
5. “*” 表示尚未開模。

1. Outer diameter shall refer to the arithmetic mean value of any 2 given O.D. at the right angle to each other.
2. Approximate weight shall be estimated by adding the minimum thickness to 1/2 of the allowable thickness tolerance at the specific gravity of 1.0.
3. PVC-DWV foam core pipes for ground water works shall be of orange color.
4. PVC-DWV foam core pipes for regular applications or telephone network cables shall be of light gray color.
5. Mark “*” means the mold is not developed yet.

- PVC-DWV管所使用之接頭與一般CNS規格之PVC射出接頭相同。
- PVC-DWV管接合所使用之膠合劑與一般PVC管相同。
- PVC-DWV foam core pipes uses the same fittings with CNS PVC fittings.
- PVC-DWV foam core pipes will be connected with CNS PVC fittings by PVC rigid adhesive.

5

PVC-DWV管規格

Specifications of PVC-DWV foam core pipes :

2. PVC-DWV管TS放口規格 : (CNS 14589)

Specification for PVC-DWV foam core pipes with TS Solvent Cement Socket :

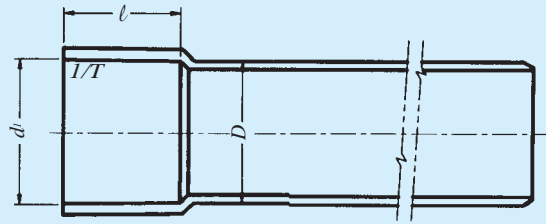

單位 : mm Unit: mm

標稱管徑 Nominal Pipe Size		D	d ¹	1/T	l
40	1 1/2"	48±0.15	48.7±0.30	1/37	55 $\begin{smallmatrix} +5 \\ -1 \end{smallmatrix}$
50	2"	60±0.15	60.8±0.30	1/56	70 $\begin{smallmatrix} +10 \\ -5 \end{smallmatrix}$
65	2 1/2"	76±0.18	76.8±0.30	1/60	90 $\begin{smallmatrix} +10 \\ -5 \end{smallmatrix}$
80	3"	89±0.20	89.8±0.30	1/64	90 $\begin{smallmatrix} +10 \\ -5 \end{smallmatrix}$
90	3 1/2"	100±0.22	100.90±0.35	1/66	110 $\begin{smallmatrix} +10 \\ -5 \end{smallmatrix}$
100	4"	114±0.23	115.0±0.35	1/68	130 $\begin{smallmatrix} +10 \\ -5 \end{smallmatrix}$
125	5"	140±0.25	141.2±0.40	1/70	150 $\begin{smallmatrix} +10 \\ -5 \end{smallmatrix}$
150	6"	165±0.28	166.4±0.45	1/72	170 $\begin{smallmatrix} +10 \\ -5 \end{smallmatrix}$
200	8"	216±0.38	217.8±0.55	1/74	220 $\begin{smallmatrix} +10 \\ -5 \end{smallmatrix}$
* 250	10"	267±0.38	269.2±0.65	1/76	270 $\begin{smallmatrix} +10 \\ -5 \end{smallmatrix}$
* 300	12"	318±0.38	320.5±0.80	1/78	310 $\begin{smallmatrix} +10 \\ -5 \end{smallmatrix}$

註/Note:

1. $1/T = \frac{d^1 - d^2}{l}$ (d²為底端之內徑 / d² as the inner diameter of the bottom)

2. "*" 表示尚未開模 / Mark "*" means the mold is not developed yet.

6

PVC-DWV管的接合施工法(TS)冷接法

Installation of PVC-DWV foam core pipes (TS unheating connection)

1. 雄管端以粗目銼刀或砂輪沿30~45°削外角，其殘留之厚度約1/3t，但不得小於1m/m，（如下圖所示）。

1. Whittle the outside angle of male pipe using a file or sander in 30~45° the remaining edge shall be of 1/3 t, but never less than 1mm (as shown below).

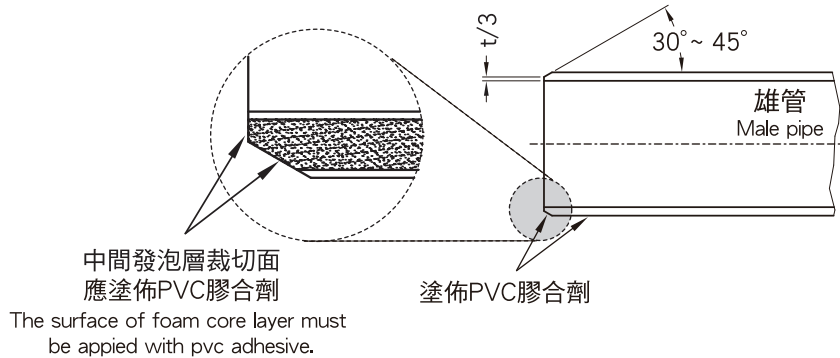

- 註：膠合施工時，雄管端表面及中間發泡層裁切面若未塗佈PVC膠合劑而造成漏水之損失，由施工人員自行負責。

- P.S.: If the pipeline was not applied pvc adhesive losses by leakage, is responsible for the installations of their own.

2. 承口內部與管端外表，用乾布擦拭乾淨，於承口內與雄管端表面及中間發泡層裁切面各塗佈PVC膠合劑，待部份溶劑揮發而膠著性增強時，則用力插入，並旋轉90°角度，使膠合劑之塗佈更為均勻。中大口徑不必旋轉，但插入後管端可墊以厚板或角材加以輕輕槌入，大口徑亦可利用動力機械拉入連接。

2. Wipe clean the inside of the fitting and outside of the pipe using a piece of dry cloth. Apply vinyl adhesive in proper quantity on the inside of the fitting and the outside of the male pipe, included the foam core surface. When the solvent becomes partially volatilized and the adhesion reinforced, insert the pipe and turn it 90° to allow even spreading of the adhesive. Do not turn pipes of medium and large diameters. Though, after the insertion, pad in by slighting hammering in a thick plate or a corner lining into the pipe end. Pipes of large diameters may also be connected using by machinery.

3. 膠合施工後不可移動，24小時後即可通水，但氣溫5°C以下之低溫施工時，膠合施工後，須經48小時後再通水。

3. When the pipes were installed by NAN YA Vinyl Adhesive do not remove the connected pipes, the pipes will start to transfer water after wait for 24 hours. But if the temperature is under 5°C, the pipes need to keep 48 hours waiting after installed, then start to transfer water.

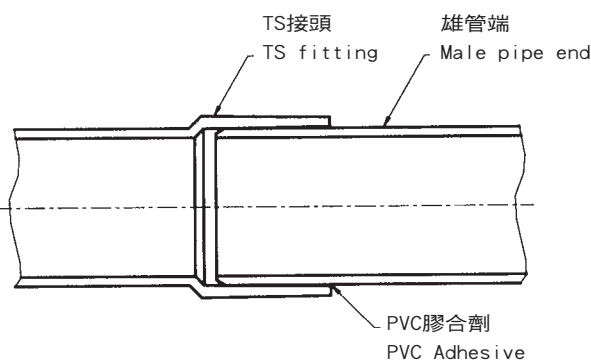

7

PVC-DWV管施工應注意事項

Instructions for installation of PVC-DWV foam core pipes

1. PVC-DWV管之接合施工與一般PVC管相同，但以採用TS冷接法為主，其使用之膠合劑亦為硬質膠合劑。
 2. PVC-DWV管露出配管之支撐距離，如下表供參考。
 3. PVC-DWV管於搬運中或施工中應防止掉落，卸貨時嚴禁用拋落的不當方法施行。
 4. PVC-DWV管施工所使用之射出接頭與一般相同為無發泡製品。
 5. PVC-DWV管不得使用於具內壓之自來水配管與一般用管。
 6. 樓板打混凝土作業中，水電工人員應常駐於工地，以便處理配管上之突發事件。
 7. PVC-DWV管與接頭，下水道用途應採用橘紅色，其他一般性無內壓用途之配管，應採用淺灰色製品。
1. PVC-DWV foam core pipes shall be installed by following the same procedure of an ordinary PVC pipe, though TS unheating connection method shall prevail and the adhesive shall be a PVC type.
 2. The following table suggests the supporting pitch for fittings protruding the PVC-DWV foam core pipe.
 3. Keep PVC-DWV foam core pipes from falling when handling or installing them. Do not drop the PVC-DWV pipes when unloading them.
 4. The injected fitting for installation of PVC-DWV foam core pipes is an ordinary product.
 5. No PVC-DWV foam core pipe shall be used for drinking water works having internal pressure and other piping of general use.
 6. During slab grouting, plumbers and electricians shall be available on the worksite for accidents.
 7. Orange PVC-DWV foam core pipes and fittings shall be used for sewerage works. Light gray ones shall be used in other non-pressure applications.

單位：m/ Unit : m

標稱管徑 Nominal diameter	縱向支撐距離 Longitudinal pitch	橫向支撐距離 Horizontal pitch
40m/m(1 1/2")~65m/m(2 1/2")	1.5	1.0
80m/m(3")~100m/m(4")	2.0	1.5
125m/m(5")以上/and up	2.5	2.0



經濟部標準檢驗局正字標記證書

廠 商 名 稱 南亞塑膠工業股份有限公司

廠 商 地 址 高雄市中山三路35之1號

代 表 人 姓 名 吳欽仁

生產製造工廠名稱 南亞塑膠工業股份有限公司嘉義廠

生產製造工廠地址 嘉義縣太保市南新里北港路2段201號

品 管 評 鑑 制 度 CNS 12681/ISO 9001 (2000年版)

產 品 名 稱 硬質聚氣乙烯塑膠芯層發泡管

適用國家標準 總號 14589 類號 K3119

證 書 號 碼 台正字第 7077 號

上記產品依標準法第11條第1項規定審查合格，
核准使用正字標記。

局長 陳 介 山

中 華 民 國 92 年 5 月 29 日

代表人姓名變更96年1月9日 換發此證





本簡介採用南亞珠光紙PH-150級
本產品不得混入紙類回收

This catalog is made by PEPA PH-150.

Do not recycle together with the natural paper.

(2009.7.1000)



南亞塑膠工業股份有限公司
NAN YA PLASTICS CORPORATION

塑膠第三事業部 · PLASTICS 3RD DIV.

台北市10591敦化北路201號 電話：(02)2712-2211

201, TUN HWA N. ROAD, TAIPEI, TAIWAN, R.O.C.

CABLE："NAN YA TAIPEI" TELEX：11246 PLASTICORP TAIPEI

FAX：(02)25140628, 25140668 TEL：(02)2712-2211

註冊第605420號商標